

8T95, 96, 97, 98 Hex Buffers/Inverters

High Speed Hex 3-State Buffers
High Speed Hex 3-State Inverters
Product Specification

Logic Products

DESCRIPTION

Each of the 3-state bus interface elements described herein has low current PNP inputs and is designed with Schottky TTL technology for ultra high speed. The devices are used to convert TTL/DTL or MOS/CMOS to 3-state TTL bus levels. For maximum systems flexibility, the 8T95 and 8T97 do so without logic inversion, whereas the 8T96 and 8T98 provide the logical complement of the input. The 8T95 and 8T96 feature a common control line for all six devices, whereas the 8T97 and 8T98 have control lines for four devices from one input and two from another input.

FUNCTION TABLE — 8T95

INPUTS			OUTPUT
DIS ₁	DIS ₂	I	Y
L	L	L	L
L	L	H	H
X	H	X	(Z)
H	X	X	(Z)

H = HIGH voltage level
L = LOW voltage level
X = Don't care
(Z) = HIGH impedance (off) state

FUNCTION TABLE — 8T96

INPUTS			OUTPUT
DIS ₁	DIS ₂	I	\bar{Y}
L	L	L	H
L	L	H	L
X	H	X	(Z)
H	X	X	(Z)

TYPE	TYPICAL PROPAGATION DELAY	TYPICAL SUPPLY CURRENT (TOTAL)
N8T95	8ns	65mA
N8T96	6.5ns	59mA
N8T97	8ns	65mA
N8T98	6.5ns	59mA

ORDERING CODE

PACKAGES	COMMERCIAL RANGE $V_{CC} = 5V \pm 5\%$; $T_A = 0^\circ C$ to $+70^\circ C$
Plastic DIP	N8T95N, N8T96N N8T97N, N8T98N
Plastic SO	N8T97N, N8T98D

NOTE:

For information regarding devices processed to Military Specifications, see the Signetics Military Products Data Manual.

INPUT AND OUTPUT LOADING AND FAN-OUT TABLE

PINS	DESCRIPTION	8T
DIS	Input	1Sul
I	Input	1Sul
Y	Output	24Sul

NOTE:

A unit load (Sul) is 50 μ A I_{IH} and -2.0mA I_{IL} .

FUNCTION TABLE — 8T97

INPUTS		OUTPUT
DIS	I	Y
L	L	L
L	H	H
H	X	(Z)

FUNCTION TABLE — 8T98

INPUTS		OUTPUT
DIS	I	\bar{Y}
L	L	H
L	H	L
H	X	(Z)

PIN CONFIGURATION

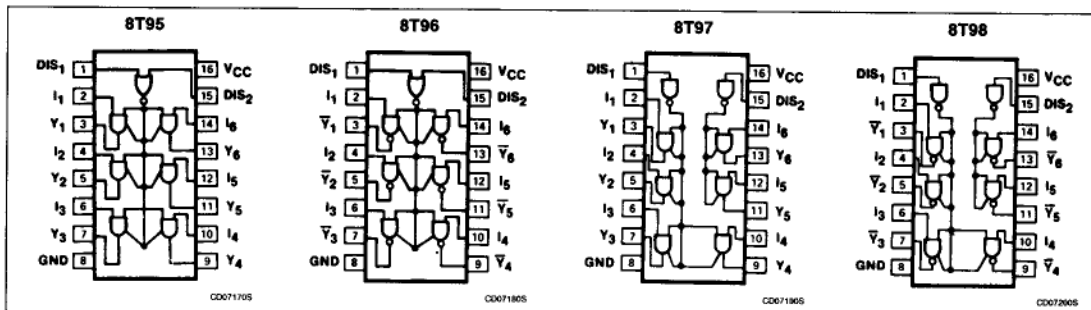

Hex Buffers/Inverters

8T95, 96, 97, 98

LOGIC SYMBOL

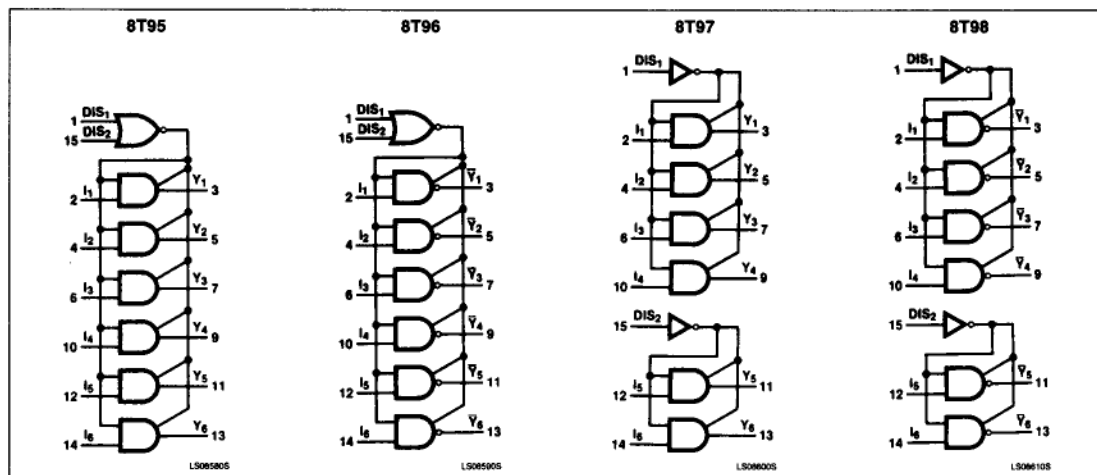

LOGIC SYMBOL (IEEE/IEC)

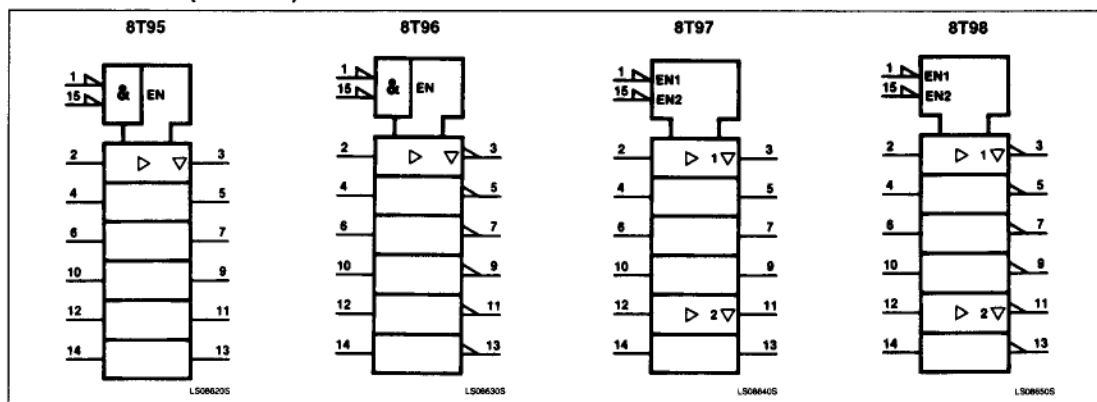

6

ABSOLUTE MAXIMUM RATINGS (Over operating free-air temperature range unless otherwise noted.)

PARAMETER	S8T	N8T	UNIT
V _{CC} Supply voltage	7.0	7.0	V
V _{IN} Input voltage	-0.5 to +5.5	-0.5 to +5.5	V
I _{IN} Input current	-30 to +5	-30 to +5	mA
I _{OL} Continuous	100	100	mA
V _{OUT} Voltage applied to output in HIGH output state	-0.5 to +V _{CC}	-0.5 to +V _{CC}	V
T _A Operating free-air temperature range	-55 to +125	0 to 70	°C

Hex Buffers/Inverters

8T95, 96, 97, 98

RECOMMENDED OPERATING CONDITIONS

PARAMETER	8T			UNIT
	Min	Nom	Max	
V_{CC} Supply voltage	4.75	5.0	5.25	V
V_{IH} HIGH-level input voltage	2.0			V
V_{IL} LOW-level input voltage			+0.8	V
I_{IH} Input clamp current			-18	mA
I_{OH} HIGH-level output current			-5.2	V
I_{OL} LOW-level output current			48	mA
T_A Operating free-air temperature	0		70	°C

TEST CIRCUIT

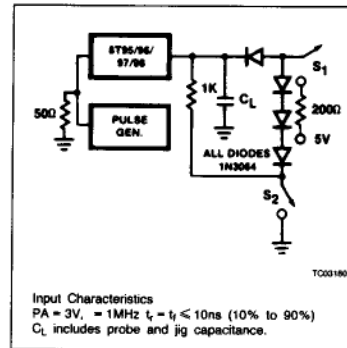

DC ELECTRICAL CHARACTERISTICS (Over recommended operating free-air temperature range unless otherwise noted.)

PARAMETER	TEST CONDITIONS ¹	8T95/97		8T96/98		UNIT
		Min	Max	Min	Max	
V_{IH} Input HIGH voltage	Guaranteed input HIGH threshold voltage	2.0		2.0		V
V_{IL} Input LOW voltage	Guaranteed input LOW threshold voltage		0.8		0.8	V
V_{IK} Input clamp diode voltage	$V_{CC} = MIN$, $I_{IK} = -12mA$		-1.5		-1.5	V
V_{BD} Input breakdown voltage	$V_{CC} = MAX$, $I_I = 1mA$	5.5		5.5		V
V_{OH} HIGH-level output voltage	$V_{CC} = MIN$, $I_{OH} = -5.2mA$	2.4		2.4		V
V_{OL} LOW-level output voltage	$V_{CC} = MIN$, $I_{OL} = 48mA$		0.5 ³		0.5 ³	V
I_{OZH} Off-state output current, HIGH-level voltage applied	$V_{CC} = MAX$, $V_O = 2.4V$		40		40	μA
I_{OZL} Off-state output current, LOW-level voltage applied	$V_{CC} = MAX$, $V_O = 0.5V$		-40		-40	μA
I_{IH} HIGH-level input current	$V_{CC} = MAX$, $V_I = 2.4V$		40		40	μA
I_{IL} LOW-level input current	$V_{CC} = MAX$, $V_I = 0.5V$	Disable = 0.5V	-400		-400	μA
		Disable = 2.0V	-40		-40	μA
I_{OS} Short-circuit output current ²	$V_{CC} = MAX$	-40	-115	-40	-115	mA
I_{CC} Supply current (total)	$V_{CC} = MAX$		98		89	mA

NOTES:

- For conditions shown as MIN or MAX, use the appropriate value specified under recommended operating conditions for the applicable type.
- I_{OS} is tested with $V_{OUT} = +0.5V$ and $V_{CC} = V_{CC} MAX + 0.5V$. Not more than one output should be shorted at a time and duration of the short circuit should not exceed one second.
- $V_{OL} = +0.45V MAX$ for S8T at $T_A = +125^\circ C$ only.

Hex Buffers/Inverters

8T95, 96, 97, 98

AC ELECTRICAL CHARACTERISTICS $T_A = 25^\circ\text{C}$, $V_{CC} = 5.0\text{V}$

PARAMETER	TEST CONDITIONS	8T95/97		8T96/98		UNIT
		$R_L = 200\Omega$		$R_L = 200\Omega$		
		Min	Max	Min	Max	
t_{PLH} Propagation delay Data inputs to data outputs	S_1, S_2 are closed, $C_L = 50\text{pF}$		12		11	ns
t_{PHL} Propagation delay Data inputs to data outputs	S_1, S_2 are closed, $C_L = 50\text{pF}$		13		10	ns
t_{PZH} Disable to outputs High Z to logic "1"	S_1 is open, S_2 is closed, $C_L = 50\text{pF}$		25		22	ns
t_{PZL} Disable to outputs High Z to logic "0"	S_1 is closed, S_2 is open, $C_L = 50\text{pF}$		25		24	ns
t_{PHZ} Disable to outputs Logic "1" to high Z	S_1, S_2 are closed, $C_L = 5\text{pF}$		10		10	ns
t_{PLZ} Disable to outputs Logic "0" to high Z	S_1, S_1 are closed, $C_L = 5\text{pF}$		12		16	ns

AC WAVEFORMS

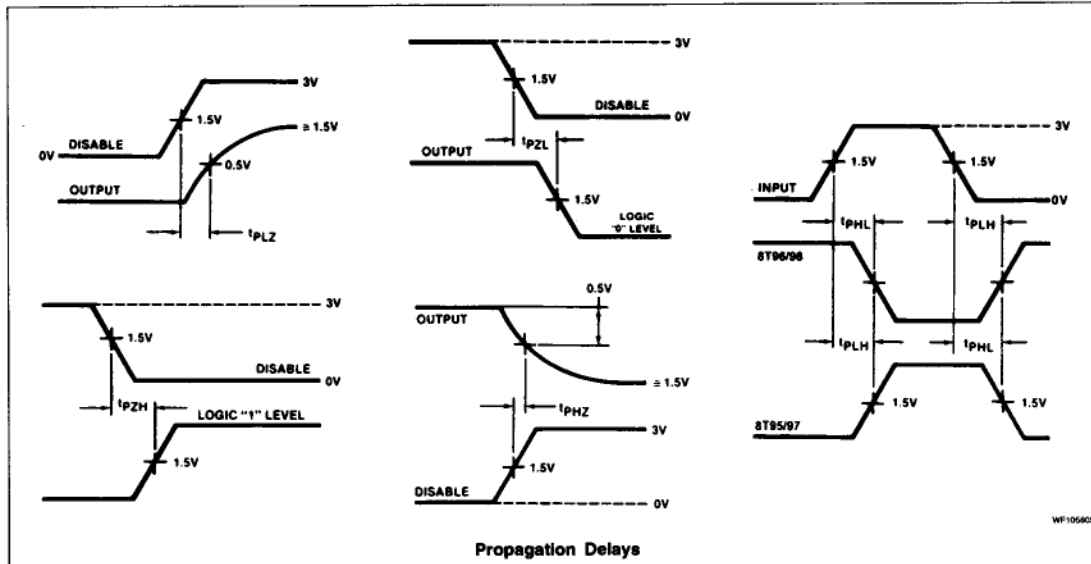

6